

Green LED Light - Non Hazardous

ELEDNH

Enware's Green LED Light is a versatile general purpose, IP65 rated, IK10 weatherproof lighting unit.

Linear LED light engines and efficient control gear provide class leading performance; protected by an IP65 impact resistant polycarbonate housing and prismatic diffuser delivering a uniform lit appearance.

Enware Green LED Light has integral long life high temperature lithium battery for emergency back up.

FEATURES

- L70 50,000hrs
- Fast fix mounting clips for rapid installation
- Uniform lit appearance, no shadowing
- 4000K colour temperature, CRI >80, IP65, IK10
- High efficiency 110 (Lm/W) linear LED light engines
- Long life LiFePO4 integral emergency battery
- Impact and heat resistant prismatic polycarbonate diffuser secured with tamperproof stainless steel clips
- Lumen output exceeds traditional fluorescent technology with reduced energy consumption
- Surface mount rear brackets supplied
- Two 20mm cable entries, one each end, supplied with IP gland.



Product Codes

ELEDNH	Non Hazardous Green LED Light
ELEDNH-B	Non Hazardous Green LED Light with Bracket

Technical Information

Operation mode	Mains, emergency maintained
Operation voltage	240V/ 50Hz, 19W - 42W
Lamp detail	LED 18W - 40W 2100lm, 4000K HF
Rating	IP65, IK10
Certification	AS2293:2005, AS/NZS CISPR15, AS/NZS60598.2.1
Standard materials	Body - PC, Diffuser - PC
Weight	2.3 kg

NOTE: Enware Australia advises: 1. Due to ongoing Research and Development, specifications may change without notice. 2. Component specifications may change on some export models.

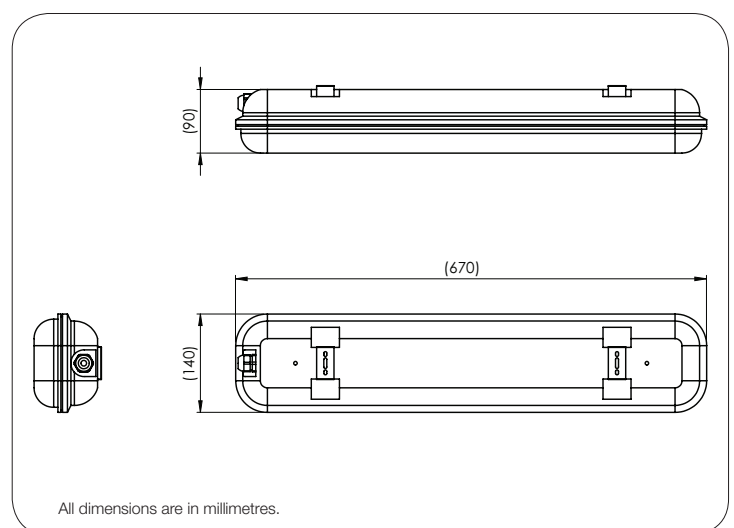

Version:Jun20

Call 1300 369 273
www.enware.com.au

Enware Australia Pty Limited
9 Endeavour Rd Caringbah NSW 2229 Australia
Ph: 02 8536 4000 info@enware.com.au

 **ENWARE**