

Freestanding Hand Operated Multi-Spray Shower and Hand Operated Eye / Face Wash with 3 Side Panels

EM660

Enware's freestanding multi-spray decontamination showers for use where hazardous substances are used. The multi-sprays ensure maximum coverage of clothing and the highest quality components ensure reliability.

KEY FEATURES

- 16 multi-spray outlets
- Hand operated multi-spray shower
- Hand operated eye/ face wash
- Three side panels for enclosed applications
- Stainless steel construction for maximum durability and reliability
- Eye/ face wash serviceable in-situ



PRODUCT CODES

EM660	Freestanding Hand Operated Multi-Spray Shower - 16 Spray and Hand Operated Eye/Face Wash with 3 Side Panels
-------	---

Version: Feb 22

Freestanding Hand Operated Multi-Spray Shower and Hand Operated Eye / Face Wash with 3 Side Panels

TECHNICAL INFORMATION

Decontamination Shower	
Inlet Connection	25mm (1" BSP) Female NPT and flange connections available for petro-chemical and offshore applications
Flow Rates	97 lpm @ 200 kPa 118 lpm @ 300 kPa 153 lpm @ 500 kPa 216 lpm @ 1000 kPa
Eye/Face Wash	
Inlet Connection	1/2" BSP male (DN 15mm) with olive compression fitting
Water Supply Line Size	Supply piping shall be adequately sized to meet flow requirements
Minimum Requirements to achieve ANSI Z358.1 and AS/NZS 4775 compliance	Min Working Pressure: 210 kPa Caution should be taken when pressure exceeds 550 kPa Minimum Flow 11.4 lpm
Enware Performance	At Working Pressure: 210 kPa Eye/Face Wash Flow 26 lpm
Waste Water Outlet Connection	G 1-1/2" BSP

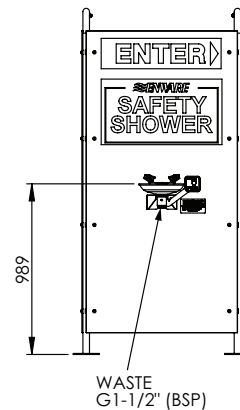
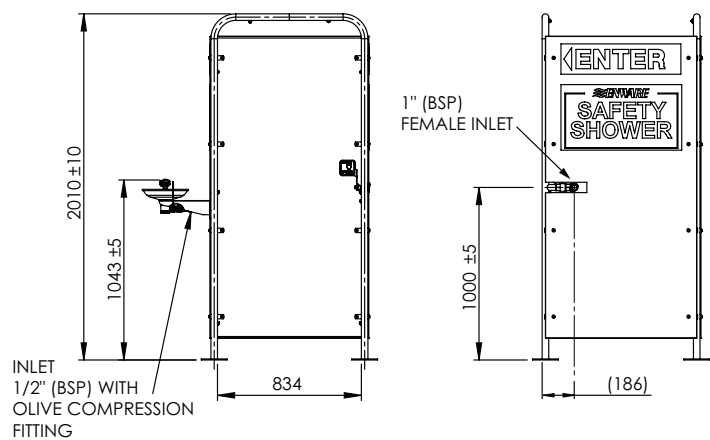
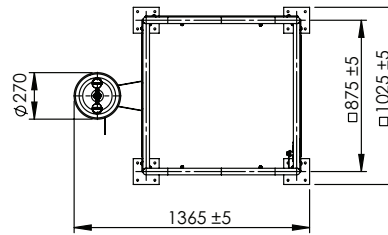

Installation of eye/face wash equipment shall be in accordance with AS/NZS4775 or ANSI Standard Z358.1 - whichever is applicable to the installation.

Enware Australia advises:

1. Due to ongoing Research and Development, specifications may change without notice. 2. Component specifications may change on some export models. 3. Refer to warranty statement for warranty details - www.enware.com.au/warranty

Version: Feb 22